



# SPECIFICATION SHEET

## PVE 30 PR

Powerful, Versatile and Efficient Piling Rig



# GĀNDARA

SU EQUIPO EN CIMENTACIÓN

High capacity, designed  
for multiple jobs per day,  
Low weight, Wide tracks

# PVE 30 PR



## PVE EQUIPMENT USA

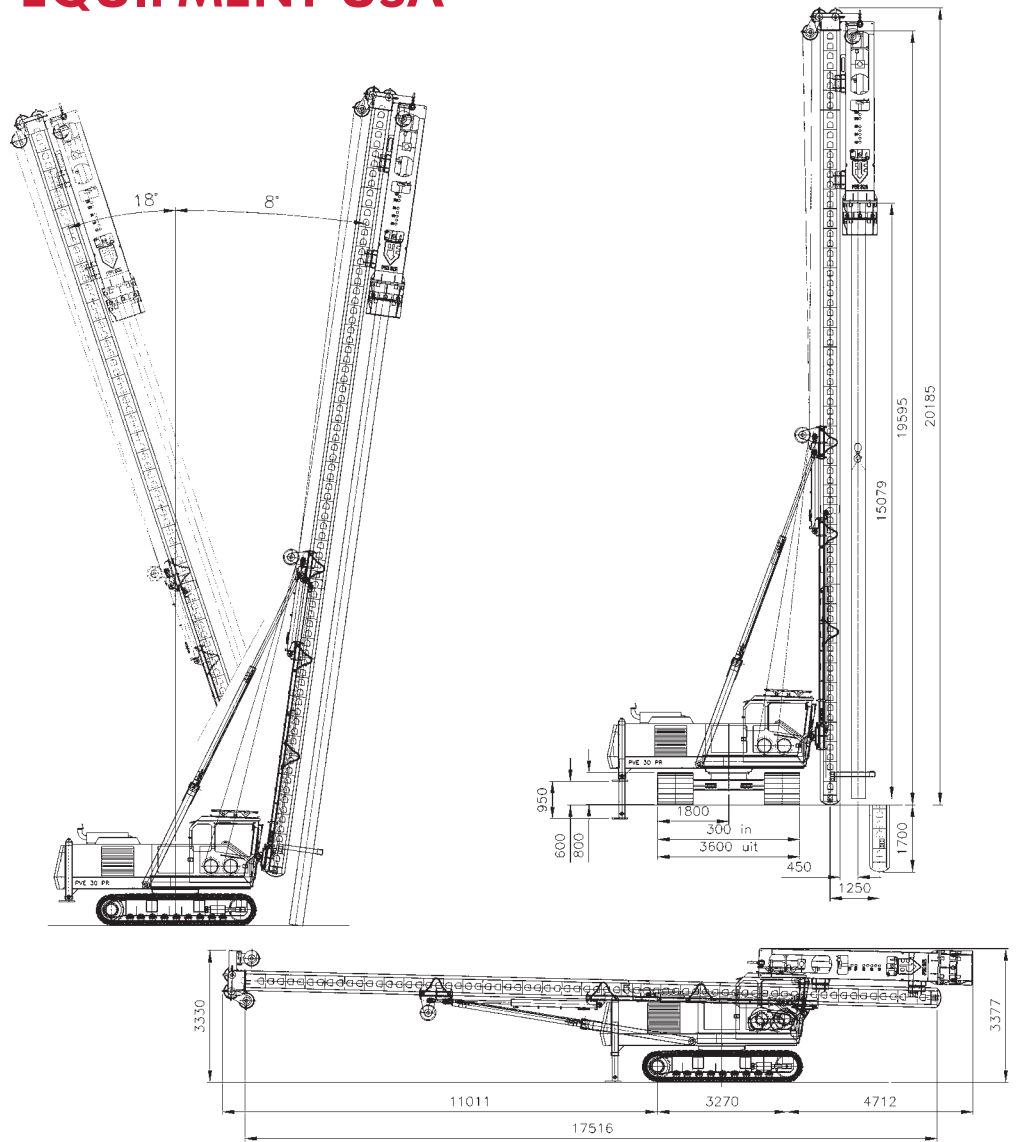

All dimensions are in millimeters

PVE is continuously improving their range of equipment. Developments in relation to emission standards and fuel efficiency might result in different specifications.

No rights can be attached to the dimensions and specifications mentioned on this leaflet because they might have changed without further notification. All data is subject printing and conversion errors.

### TECHNICAL SPECIFICATIONS

Max. pile & hammer weight	22,046 lbs (10 ton)	Hydraulic system	Open Loop
Capacity hammer winch	13,228 lbs (6 ton)	Hydraulic pumps	Bosch-Rexroth
Capacity pile winch	13,228 lbs (6 ton)	Hydraulic valve blocks	Bosch-Rexroth
Capacity optional aux. winch	8,818 lbs (3 ton)	Transport width	9.84 ft (3.000 mm)
Leader length	57.41 ft (17,5 m)	Transport length	59.06 ft (18.000 mm)
Max. leader length	63.98 ft (19,5 m)	Transport height incl. hammer	11.48 ft (3.500 mm)
Diesel engine	Caterpillar C-7	Transport height excl. hammer	10.93 ft (3.330 mm)
Output diesel engine	250 HP / 183 kW	Transport weight excl. hammer	66,139 lbs (30 ton)

PVE Equipment USA Inc. P.O. Box 12529 5011 Vernon Road Jacksonville, FL 32209, USA  
 T 904 765 6686 W pve-equipment.com

