



# SPECIFICATION SHEET

## PVE 40 PR

Powerful, Versatile and Efficient Piling Rig



# GÁNDARA

SU EQUIPO EN CIMENTACIÓN

High capacity,  
assemble,  
CAT engine,

Very quick to  
Fast and efficient, Very reliable,  
New type of Cabin

# PVE 40 PR



## PVE EQUIPMENT USA

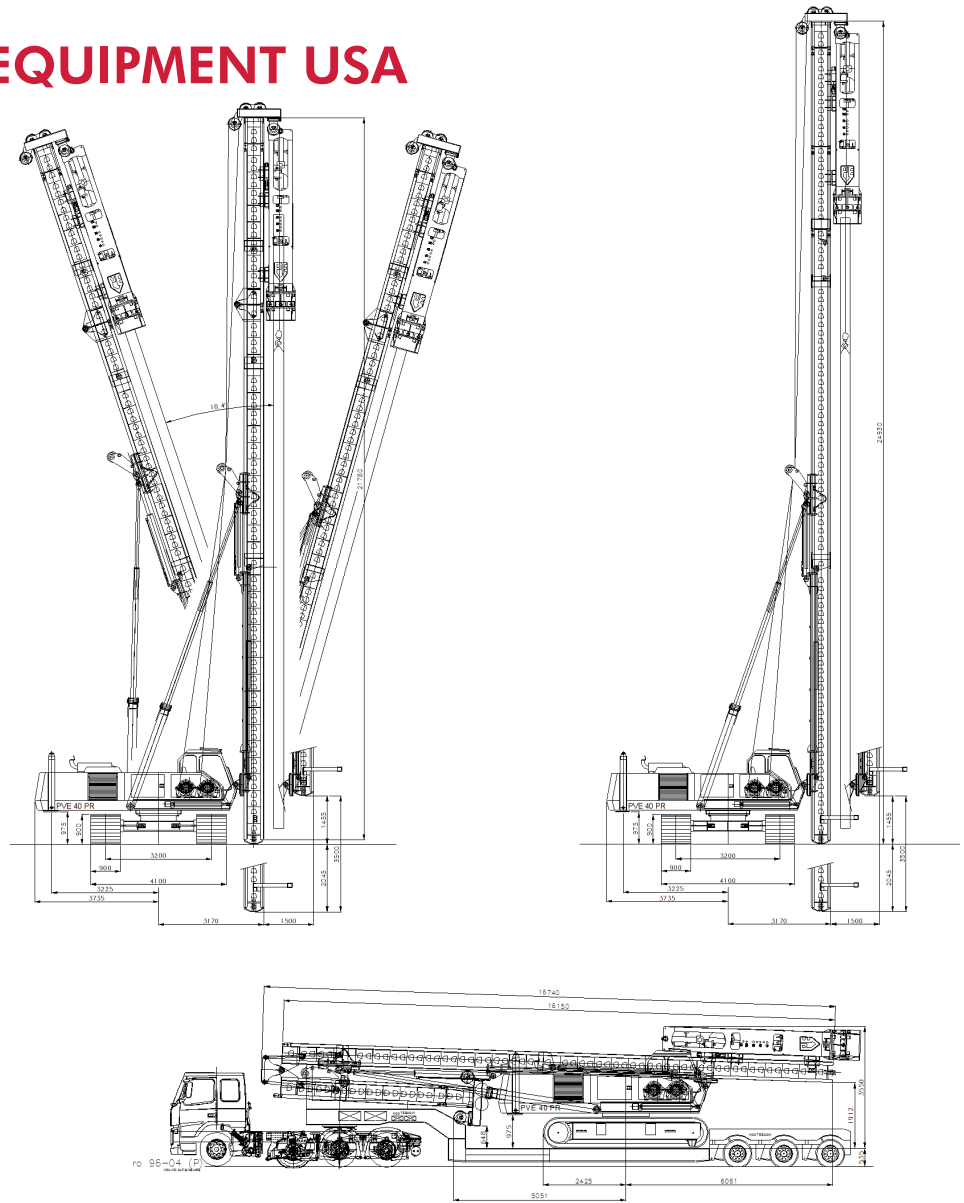

PVE is continuously improving their range of equipment. Developments in relation to emission standards and fuel efficiency might result in different specifications. No rights can be attached to the dimensions and specifications mentioned on this leaflet because they might have changed without further notification. All data is subject printing and conversion errors.

All dimensions are in millimeters

### TECHNICAL SPECIFICATIONS

Max. pile & hammer weight	28,660 lbs (13 ton)
Capacity hammer winch	17,636 lbs (8 ton)
Capacity pile winch	13,228 lbs (6 ton)
Capacity optional aux. winch	6,613 lbs (3 ton)
Standard leader length	71.5 ft (21,8 mtr)
Maximum leader length	81.3 ft (24,8 mtr)
Diesel engine	Caterpillar C-7
Output diesel engine	250 HP / 183 kW
Emission regulation	TIER 3/4

Hydraulic system	Open Loop
Hydraulic pumps	Rexroth
Hydraulic valve blocks	Rexroth
Transport width	10.83 ft (3.300 mm)
Transport length	54.92 ft (16.740 mm)
Transport height	11.65 ft (3.550 mm)
Recommended hammer	PVE 4NL
Weight base machine	88,185 lbs (40 ton)

PVE Equipment USA Inc. P.O. Box 12529 5011 Vernon Road Jacksonville, FL 32209, USA  
T 904 765 6686 W pve-equipment.com

