



Özkanlar Horizontal Thrust Boring Machines are designed to bore the inevitable need of many public works and construction applications, the coated holes of diameter between 12" and 120".



It is the essential equipment in your horizontal pipe driving applications through several kinds of highways, roads and railroads.

The hydraulic system, by combining the design of easy use with the torque it forms when needed, will provide maximum safety while the machine is on hold.



Fast and easy usage, efficient performance and outstanding power and engineering are the features of Özkanlar Horizontal Thrust Boring Machines.



To watch the animation scan the QR code.

www.ozkanlarmakina.com.tr

ÖZKANLAR
MAKİNE

Horizontal Thrust Boring Machines

Boring method is the procedure to drive the pipes whose diameter varies between 250 mm – 1800 mm through auger horizontal drill. With this method, all kinds of highway, railway, passing can be managed. At the lines where Cover Steel Pipes should be used, ÖYS Series horizontal pipe jacking machines which we manufacture and sell and which work with the method of drilling and discharging are used.

TEKYÖN
TÜNEL

ÖZKANLAR
MAKİNE

VIBROFLOTASYON

VIBRO HAMMERS

ÖZKANLAR
GRUP

ASO 1. Organize Sanayi Bölgesi, 5. Kısım,
Anadolu Caddesi, No: 7, Sincan / Ankara
www.tekyontunel.com • www.ozkanlarmakina.com.tr
E-Mail: ozkanlar@ozkanlarmakina.com
T. +90 312 386 05 60 • F. +90 312 386 05 68

[youtube.com/user/ozkanlarmakina](https://www.youtube.com/user/ozkanlarmakina)
 tr.linkedin.com/in/ozkanlarmakina
 facebook.com/ozkanlarmakina
 twitter.com/ozkanlarmakina

google.com/+ozkanlar
 pinterest.com/ozkanlarmakina
 ozkanlarmakina.tumblr.com
 flickr.com/ozkanlarmakina

GÁNDARA
SU EQUIPO EN CIMENTACIÓN

Cristóbal de Olid # 498, Col. Reforma
Veracruz, Ver. México C.P. 91919
Teléfono: +52(229)100-22-01
info@gandara.com.mx
www.gandara.com.mx

First Phase



Once the entrance and exit points are determined, necessary topographic measurements and job site studies are completed; a line mark is formed. Possible damages (like water, telecommunication, sewerage and electricity energy transmission networks) that may occur during shaft and tunnel excavation is checked and if necessary the transition code is identified by displacing.

Second Phase



The excavation of the shaft which is convenient for the Project which is prepared according to the sizes of the machine to be used, diameter of the pipe and passing altitude is taken. Then, the formwork is set, the reinforcement is prepared, hip and base concrete is laid. If necessary, the side partition walls are made. Unless there is no danger considering the job safety, the partition walls have no contribution to the horizontal drilling.

Third Phase



The walking rails of the machine are located in the chimney by a crane, and are located on the base concrete. The walking rails are adjusted according to the drilling axle. The middle axle of the rail should match with the drilling axle.

Fourth Phase



The augers are located in the steel pipes which are 6m in length and in enough thickness (minimum %1 thickness (of the diameter)). The pipe is carried safely by a crane after the balance

point is identified; and is located in the chimney. The connection socket of the auger is fixed to the rotation housing of the machine. The fixation pin and cotter pin are mounted. Once the auger is connected to the machinery, pipe to be laid is abutted on the pushing mechanism of the machine and the drilling head is put on the starting point. Then, the drilling process starts.

Fifth Phase



After the auger arrives at the end, the rotation movement stops. The machine is withdrawn by the pipe length, and the other pipe which has an auger in is lowered. By welding, this

process goes on till the line ends. Meantime, by entering in the pipe at certain intervals, direction and pitch controls are done and the line is completed.

Dimensions

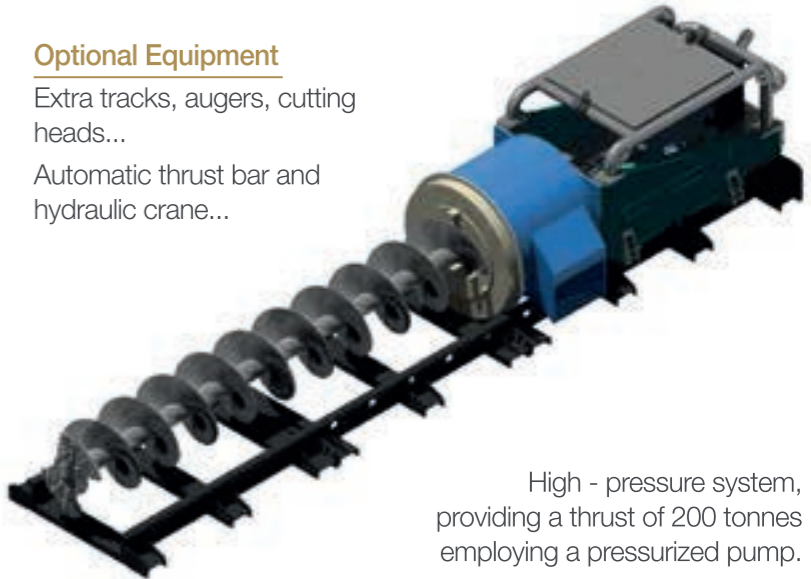

Optional Equipment

Extra tracks, augers, cutting heads...
Automatic thrust bar and hydraulic crane...

High - pressure system, providing a thrust of 200 tonnes employing a pressurized pump.

Cutting Heads

Özkanlar Cutting Heads are designed to be long-lasting and at maximum efficiency boring applications.

Heavy-Duty Rocky Heads

These tough and proven heads are at a shape of "V" for self-centralization, which results in a directional move. They are ideal in rocky and relatively less hard environments with fast substituted cutting heads.

Combination of Heads

Rocky and soil cutting heads are ideal in environments with big rocks, soft rocks and clayey soils.

Mud Cutting Heads

These high - quality cutting heads are applicable in boring works in all places except rocky ones. They are recommended for horizontal pipe driving of diameter less than 300 mm.

Technical Specification

| | ÖYS 42 | ÖYS 60 | ÖYS 72 |
|----------------------------|---------------------|--------------------------------|-------------------------|
| Diesel Engine Brand/ Power | Magurus 912 / 80 HP | 160 HP Diesel / Chrysler T. I. | 180 HP Diesel / Perkins |
| Transmission | 3 ileri 1 geri | 6 ileri 1 geri | 6 ileri 1 geri |
| Thrust | 115 ton | 544 tons | 544 tons |
| Track Length (TL) | 3 x 3.00 m | 2 x 3.00 m, 1 x 4.20 m | 1 x 4.20 m |
| Drive | 12.70 mm/s | 8.33 mm/s | 6.50 mm/s |
| Height (H) | 1000 mm | 1551 mm | 2100 mm |
| Length (L) | 3135 mm | 4128 mm | 4240 mm |
| Width (W) | 1200 mm | 2134 mm | 2150 mm |
| Weight | 3450 kg | 8500 kgs | 12500 kgs |
| Drilling Diameter | 10" - 42" | 20" - 60" | 24" - 72" |

