



To watch the animation
scan the QR code.

www.ozkanlarmakina.com.tr

ÖZKANLAR
MAKİNE

THDD 450

Horizontal Directional Drilling Machine

Horizontal Directional Drilling Machine can be transport with trailer, has 45 ton capacity. It is possible to install pipes up to Ø1200 mm and 2000 meter long under surface.

TEKYÖN
TÜNEL

ÖZKANLAR
MAKİNE

VIBROFLOTASYON

VIBRO HAMMERS

ÖZKANLAR
GRUP

ASO 1. Organize Sanayi Bölgesi, 5. Kısım,
Anadolu Caddesi, No: 7, Sincan / Ankara
www.tekyontunel.com • www.ozkanlarmakina.com.tr
E-Mail: ozkanlar@ozkanlarmakina.com
T. +90 312 386 05 60 • F. +90 312 386 05 68

[youtube.com/user/ozkanlarmakina](https://www.youtube.com/user/ozkanlarmakina)
 tr.linkedin.com/in/ozkanlarmakina
 facebook.com/ozkanlarmakina
 twitter.com/ozkanlarmakina

google.com/+ozkanlar
 pinterest.com/ozkanlarmakina
 ozkanlarmakina.tumblr.com
 flickr.com/ozkanlarmakina

GANDARA
SU EQUIPO EN CIMENTACIÓN

Cristóbal de Olid # 498, Col. Reforma
Veracruz, Ver. México C.P. 91919
Teléfono: +52(229)100-22-01
info@gandara.com.mx
www.gandara.com.mx

1. Pilot (Guide) Bit

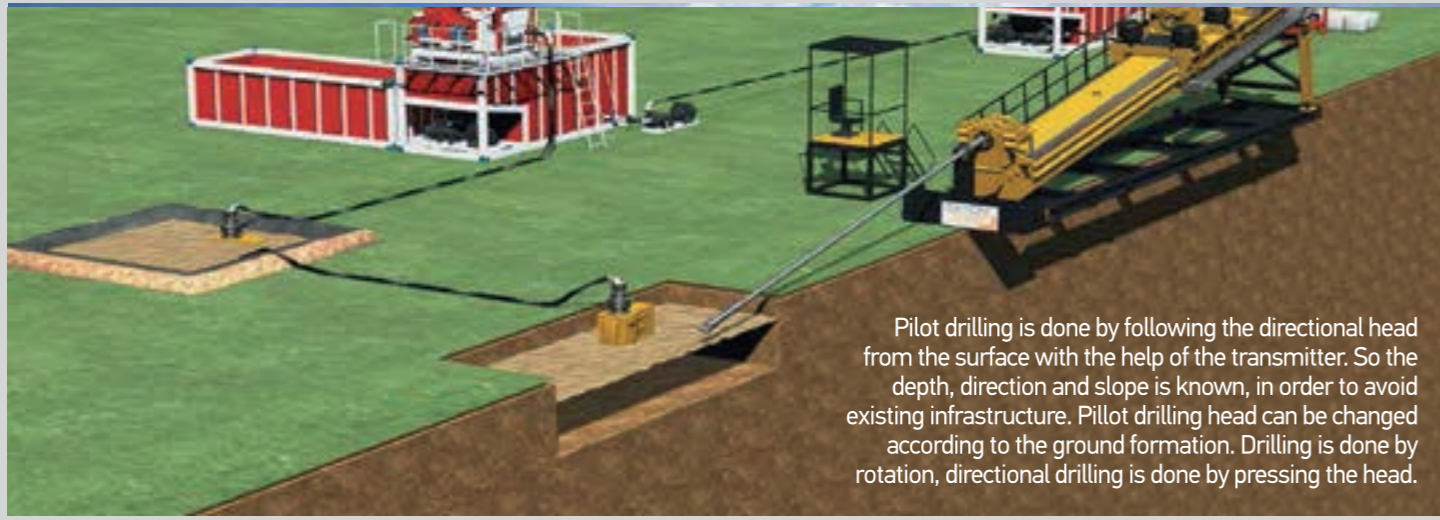

2. Enlarging



3. Pipe Pulling Process

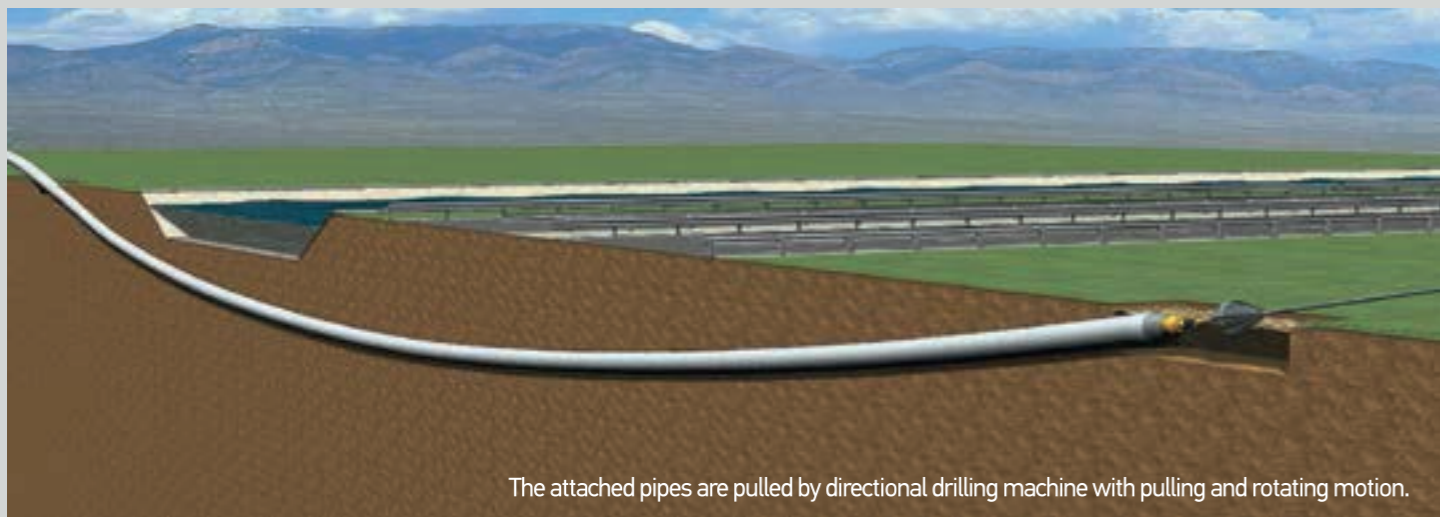

Dimensions

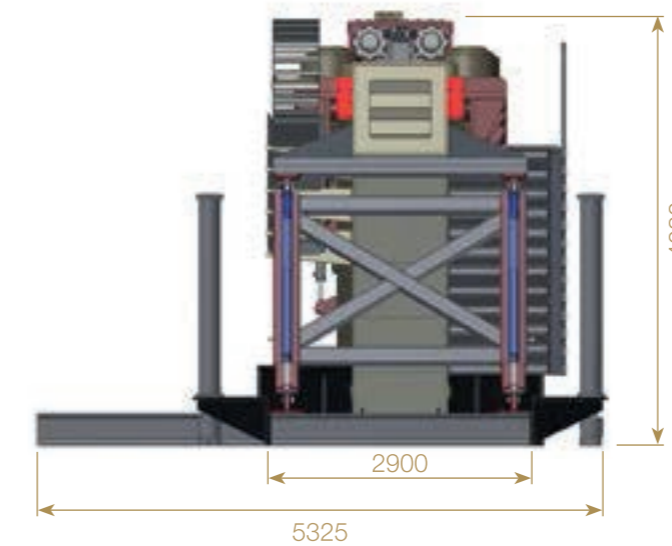

THDD 450 Horizontal Directional Drilling Machine with 450 tons pulling capacity is the first in Turkey and one of the leading in the world manufactured by Özkanlar Machinery.

Technical Specification

Pullback Force (Max)	4500 Kn
Carrige Speed	0 - 25 m / min
Travel Distance (Max)	10.000 mm
Rotary Torque (Max)	120 kN
Clamping Range	140 - 250 mm
Breakout Torque (Max)	160 kN
Make-Up Torque (Max)	110 kN
Power Pack	768 HP / 565 kW
Power Transmission	Kremayer & Pinyon Dişli
Transport Dimension (L/W/H)	16,5 / 2,9 / 4,1 m
Weight	45.650 kg

